

# LESSON 4

## Timber Cruise

### NUTSHELL

In this lesson, students conduct a timber cruise of their school forest to identify the species of trees, volumes of timber, and basal area on the property. Students work in small groups to collect data and use Kruzer software to analyze the complete class data set.

### BIG IDEAS

Different types of forests exist within a biome. Some of the types of forests in Wisconsin include **coniferous**, **deciduous**, and deciduous and coniferous mixes. (Subconcept 5)

Forest management is the use of techniques (e.g., planting, harvesting) to **promote**, **conserve**, or **alter** forests to meet desired outcomes. (Subconcept 34)

Forests can be managed for ecological (e.g., water resources, wilderness, wildlife), economic (e.g., forest products, recreation), and social (e.g., aesthetic appreciation, recreation) outcomes. Many of these outcomes are interrelated and can be managed for simultaneously. (Subconcept 36)

The type and intensity of forest management is dependent on desired outcomes, **forest type**, ownership, parcel size, and location. (Subconcept 43)

### OBJECTIVES

Upon completion of this lesson, students will be able to:

- Utilize forestry tools to measure the diameter and merchantable height of trees.
- Calculate merchantable tree volumes and basal area using Kruzer software.
- Assess the tree stocking and volume of an area of the school forest.

### SUBJECT AREAS

Math

Agriculture

Science (Earth, Life, Environmental)

### LESSON/ACTIVITY TIME

Total Lesson Time: 5 hours

#### Time Breakdown:

Introduction – Forest inventory – 10 minutes

Activity 1 – Forest measurements – 30 minutes

Activity 2 – Fixed area plot measurements – 90 minutes (optional)

Activity 3 – Calculating plot measurement data – 45 minutes (optional)

Activity 4 – Developing a cruising protocol – 60 minutes

Activity 5 – Kruzer cruise – 60 minutes

Activity 6 – Kruzer calculations – 30 minutes

Conclusion – Utilizing Kruzer data – 30 minutes

## TEACHING SITE

Classroom, computer lab, and forested site

## VOCABULARY

**Angle gauge:** A tool used to estimate the basal area of an acre of forest. It is designed so that each tree sample from a center point represents a pre-determined amount of basal area (this is its basal area factor) in an acre.

**BAF:** Basal Area Factor – the calibration of an angle gauge to determine the amount of basal area each sampled tree represents.

**Basal Area:** the surface area in square feet of a cross-section of a tree at breast height (4 ½ feet above the ground). It is a measure of tree crowding or density.

**Biltmore Stick:** A graduated rule used to estimate the diameter of a standing tree.

**DBH:** Diameter at Breast Height, the diameter of a tree at 4 ½ above the ground.

**Fixed-Area Plot:** A plot that is of uniform and pre-determined size.

**Kruzer:** A software program developed by forester Kris Wimme and used by the Wisconsin DNR to calculate basal area and forest product volumes utilizing variable-radius plot data.

**Merchantable Height:** the height of the tree that can be used to make forest products.

**Merritt Hypsometer:** a graduated rule used to measure the height of standing trees.

**Plot:** A measured area of land.

**Pulpwood:** Part of a tree used to make pulp for paper and related products. Six inches is the minimum DBH and four inches is the minimum diameter at the small end for all species.

**Sawlog:** A part of a tree large enough and of high enough quality to produce lumber or other products that are sawed from the tree. Eleven inches is the minimum DBH and 10 inches is the minimum diameter at the small end for deciduous (hardwood) sawlogs. Nine inches is the minimum DBH and 8 inches is the minimum diameter at the small end for conifer (softwood) sawlogs.

**Stand:** A contiguous group of sufficiently uniform trees as to be distinguished as a unit.

**Stick:** A merchantable eight-foot section of a tree.

**Stocking:** The amount of anything in a given area. In forestry, this is an indication of growing space relative to a standard. It helps determine management options in a stand.

**Timber Cruise:** A forest survey to quantify the merchantable forest products in a given area.

**UpDOB:** The diameter of the pulpwood stick at 4 ½ feet above the last sawlog

**Variable-Radius Plot:** A plot that is of undefined size. It is determined by sampling with an angle gauge or prism.

## MATERIALS LIST

### Activity 1

#### *For the Teacher*

- Copy of Teacher Page 📄1, *Forest Measurement Calculations Key*

#### *For Each Student*

- Copy of Student Page ✍1, *Forest Measurement Calculations*
- Calculator

### Activity 2

#### *For Each Student*

- Copy of Student Page ✍2, *Fixed Area Plot Data*

#### *For Each Group of 4*

- 2 Tree Scale Sticks
- Clipboard
- 100' tape measure
- Pin or stake to mark plot centers

### Activity 3

#### *For Each Student*

- Completed copy of Student Page *2*, *Fixed Area Plot Data*
- Copy of Student Page *3*, *Board Feet Table*
- Copy of Student Page *4*, *Data Summary for Fixed Area Plot*
- Calculator

### Activity 4

#### *For The Teacher*

- Copy of Teacher Page *2*, *Considerations for Developing a Timber Cruise*
- Angle gauge

#### *For Each Student*

- Kruzer tally sheet
- Kruzer species codes
- Kruzer instruction sheet

### Activity 5

#### *For Each Group of 4*

- Kruzer tally sheet
- Kruzer species codes
- Kruzer instruction sheet
- 2 Tree Scale Sticks
- Clipboard
- 100' tape measure
- Angle gauge
- Compass
- fGIS map/photo of the area of the forest to be inventoried

### Activity 6

#### *For The Teacher*

- Kruzer program, computer, projector

#### *For Each Group of 4*

- Access to Kruzer program

### Conclusion

#### *For Each Student*

- Kruzer "output" sheet of group's data
- Copy of Student Page *5*, *Kruzer Data Summary*
- Computer access to Student Page *6A-O*, *Forest Types and Stocking Charts* OR one paper copy per group of 4 students.

## **TEACHER PREPARATION**

- Use your fGIS maps to determine an area of the forest to be inventoried. Approximately 10 acres is needed. A uniform area is best, but not critical. Select the center point of the area to serve as a meeting point.
- Download the Kruzer spreadsheet onto the computers that will be used by students. One computer per group of four students should be sufficient. Contact LEAF at [leaf@uwsp.edu](mailto:leaf@uwsp.edu) to request the Kruzer program to be sent to you electronically.

## SAFETY PRECAUTIONS

Visit the teaching site ahead of time to locate any hazards such as holes, hanging branches, protruding tree roots, poison ivy, etc. Encourage students to walk at all times. Consider these:

- Are you in sight or earshot of students?
- Are boundaries for students marked?
- Have you set expectations for being out of the classroom?
- Do you have a water, whistle, first aid kit, insect repellent, water, and sunscreen?
- Is everyone dressed appropriately?

## BACKGROUND INFORMATION

A timber inventory (cruise) is conducted to estimate the volume of merchantable material in an area and to determine the density and species of the trees growing in the area. Inventories can be conducted in different ways. An inventory can use fixed-area plots, in which plots of a certain size are spread throughout the area. An inventory can also use variable-radius plots in which plot centers are determined, but the size of the plot is determined by using an angle gauge to select the trees to be sampled.

The information can be used to determine what, if any, management activities should occur in the area, assess the diversity of tree species in the area, estimate the volume of forest products that might be produced in the area, compare an area to other areas, and assess changes to the forest through time.



## PROCEDURE

### INTRODUCTION

1. Ask the students to write a definition of the verb “inventory.” After a couple minutes, ask a few students to share their definitions. If necessary, lead the class to consensus on a definition of “inventory” that is similar to “taking account of what exists somewhere.” Ask the students what could be inventoried at school forests. (*Trees, other plants, wildlife, and trails.*)
2. Explain to the students that they are going to be involved in a process to inventory the merchantable volume of trees in an area of the school forest. Define merchantable volume of trees as that portion of trees that can be made into forest products such as lumber and paper. Tell the students that foresters refer to conducting an inventory of the merchantable volume of trees as “cruising.” Introduce the other vocabulary words.

### ACTIVITY 1 – FOREST MEASUREMENTS

1. Discuss how volume is determined. Explain that volume is a 3-dimensional value, so the object’s area and depth or height need to be known (this could also be related as its width, length, and height). Next, ask students how they would determine the volume of tree. As a clue, ask students what approximate geometric shape they would consider a tree to be (*cone or tapered cylinder*). The volume of a tree can be estimated using the formula for the volume of the frustum of a cone, which is  $V = (\pi)h/12(D^2 + Dd + d^2)$  where h=height, D=bottom diameter, d=top diameter, pi=3.14. To calculate the volume of a tree, its height and diameter at the bottom and the top need to be known.
2. Ask the students what parts of the trees aren’t used to make products. (*The very tops and branches.*) Discuss with the students that when making calculation of a tree’s volume, foresters are generally interested in the merchantable volume. That is, the volume of the tree that will actually be made into a forest product. For pulp wood (used to make paper products), the minimum diameter is generally 4 inches on the small end. For logs (used for lumber), 10 inches is the minimum diameter at the small end for hardwood trees and 8 inches is the minimum diameter at the small end for softwood trees. Crooked, forked, rotten, and split trunks are not merchantable.

3. Another commonly used forest measurement is basal area. Explain to students that basal area is the surface area of a tree at breast height (4 ½ feet above the ground). Ask students what measurement would be needed to calculate the basal area of a tree. As a clue, ask them what approximate shape the cross-section of a tree is (circle). Basal area is calculated using the formula to calculate the area of a circle ( $\text{Area} = (\pi)r^2$ ). Since measuring radius of a standing tree isn't practical, we measure diameter and later convert it to radius. To determine the basal area of a tree, the diameter at breast height (DBH) needs to be measured.
4. Hand each student a copy of Student Page  1 *Forest Measurement Calculations*. Using Teacher Page  1, *Forest Measurement Calculations Key* as a reference, explain the formulas and help the students calculate the volume and basal area of a tree with the dimensions provided.
5. After completing the worksheet, share with students that the calculation for volume is a simplification of the formula used to calculate tree volumes. Ask students why the tree volume formulas are more complicated (*Trees aren't perfect geometric shapes, different trees grow in different proportions [height compared to diameter], there is waste in cutting and processing a tree*). In fact, tables have been developed to more accurately determine volume based on height and diameter measurements. However, the simplified calculations they just did will help them to understand the measurements involved in cruising.

## ACTIVITY 2 – FIXED AREA PLOT SURVEY



1. Tell students that in this activity, they will practice making forest measurements and determining basal area and merchantable volume. Begin by taking students to the area you have determined ahead of time for the survey. Ask the students to reflect back to the previous activity and think about what measurements they will need to take to determine merchantable volume and basal area. Explain to the students that they will be conducting their survey in fixed area plots. That is, they will measure all of the trees in a given area – a plot. The size of each of the plots will be 1/50<sup>th</sup> of an acre. They will be working in teams to measure the DBH (diameter at breast height) and merchantable height of each tree in their plots. They will use this information to calculate basal area and merchantable volume of their plots.
2. Tell students that they will learn to use Biltmore sticks. Take students to an outdoor area where you have three trees marked. Divide students into teams of four.
  - Show your students how to stand with arm extended so that the stick is 25" from their eye (the calibrated distance from the eye to the Biltmore Stick) holding the stick horizontally against the tree at about 4.5 feet above the ground. Explain that this height is also called DBH or diameter at breast height. The graduations should be on the upper edge of the stick. (Holding the stick from underneath prevents the graduations from being blocked by their hands.)
  - Explain that they need to look at the tree straight on, without turning their head while taking the measurement. In this position, show your students how to line up the zero end of the stick with the left edge of the tree. Now that the stick is in position, it should not move or rotate.
  - Show your students how to shift their eyes to look at the place where the right side of the tree crosses their stick. At that point, take a reading. This is the diameter in inches.
3. Give each team of four two Biltmore sticks to use. Give students time to practice.

4. Now show your students how to use a Merritt hypsometer. Explain to students that measurements taken with the Merritt rule need to be taken the distance of one chain from the tree. Define the word chain as a unit used to measure distance. One chain equals 66 feet.
  - Ask one student to hold the end of a tape measure next to the base of a tree. Holding the other end of the tape measure, walk 66 feet from the tree in a direction from which you will have a good view of the tree. Ask the class to gather around you as you stand 66 feet from the tree.
  - Explain to students that if this tree were to be harvested, not all of it would get used. In other words, the entire tree is not merchantable. Logs smaller than eight inches (conifers) or ten inches (deciduous) in diameter cannot be used for lumber. Show your students how to use a pencil to estimate where the tree is no longer eight inches in diameter. Hold a pencil at arm's length and line it up with the trunk of the tree you are measuring. From this distance (66 feet), the point where the pencil is the same width as the trunk is approximately eight inches.
  - Also explain that trees are not cut right at ground level. There is usually a one foot stump. This is where measurement begins.
  - Hold the stick vertically at arm's length so that the stick is 25" from their eye (the calibrated distance from the eye to the Merritt Hypsometer). Adjust the stick so that the zero end of the stick lines up with stump height. Show students how to look up to the point where the tree is no longer eight or ten inches in diameter. This is where they should read the number of logs in the tree from the Merritt rule on their stick (NOTE: the scale on the stick is in 16' logs. You will be recording 8' logs). Round down to the nearest 8' log.
  - **NOTE:** Some trees have forks, bends or other defects that reduce the usable height. Explain that these things should be taken into consideration when measuring merchantable height.
5. Give your students time to practice.
6. Describe and demonstrate to the students how to establish the plots. Each plot will be 1/50<sup>th</sup> of an acre, which corresponds to a radius of 16.7 feet (16' and 8"). After identifying a plot center, stretch out the tape measure to identify which trees are in the plot and which trees are out of the plot. The group will measure the height and DBH of all the trees in the plot that have a DBH of 6" or greater.
7. Explain that each member of the team will have a specific responsibility. Each team will establish and survey four plots so that each team member gets to serve in all of the roles and get experience using the tools. One student will have the clipboard and four copies of Student Page *2, Fixed Area Plot Data*. Another student will have the tape measure. Two students will have tree scale sticks. Review the roles of each of the team members: clipboard = recorder, tape measure = plot master, tree scale stick #1 = DBH measurer, tree scale stick #2 = merchantable height measurer.
8. Remind them that the teams' job is to record the necessary measurements for all trees 6 inches in DBH and larger. Review Student Page *2, Fixed Area Plot Data* with them.
  - Specifically review the size classification (Sawlogs and pulpwood). Explain that for sawlogs (used for lumber and similar products), 11 inches is the minimum DBH and 10 inches is the minimum diameter at the small end for deciduous (hardwood) trees.
  - Nine inches is the minimum DBH and 8 inches is the minimum diameter at the small end for conifer (softwood) trees.



- For pulpwood (used to make paper or similar products), 6 inches is the minimum DBH and 4 inches is the minimum diameter at the small end for all species.
  - Forked, rotten, split, and excessively crooked trunks are not merchantable.
  - A log or stick is equal to 8 feet in height (note that on tree scale sticks, # of logs is often given in # of 16' logs).
  - For trees with sawlogs, the trunk above where the sawlogs end can be used for pulpwood. In addition to the number of logs in those trees, have students estimate the number of sticks of pulpwood above the logs.
  - Tell them that the last two columns of the data sheet (basal area and sawlog volume) will be completed later.
9. Instruct students to establish their first plot. The plots' exact location isn't important, but should be within site of the group's central location. Have students complete the survey for plot #1. After completion of plot #1 (about 15 minutes), gather the groups to discuss any challenges. When confident that students are comfortable with what they are doing, have them conduct 3 additional plots. They can place the plots wherever they want, as long as each plot does not overlap one of their previous plots.

### ACTIVITY 3 – PLAYING WITH THE DATA

1. In the field or in the classroom, utilize the data collected in the fixed area plots to calculate basal area, sawlog volume, and pulpwood volume. Have students work individually to do the calculations, with each student using one of the four plot data sheets that the team has completed. When each of the students in the group is done with the calculations, they should rotate data sheets and check each other's calculations. Explain the calculations they will be doing on the plot data sheets, Student Page , *Fixed Area Plot Data*, as outlined below.
  - Ask the students what basal area is (*The surface area of a tree cut off at breast height – 4 ½ feet*). Ask what measurement is needed to calculate basal area (*diameter*). The basal area calculation is  $BA = \pi r^2$ . DBH in inches is divided by 12 to convert it to feet. It is then divided by two to get the radius of the tree. Students will be calculating the basal area of each tree and then adding those to get the basal area of the plot.
  - Sawlog volume is reported in board feet. A board foot is 12" X 12" X 1". One board foot is equal to 0.083 cubic feet. The best way to calculate board feet is using a sawlog volume table. These tables are determined using more complex volume formulas that take into account the generalized shape of trees, thickness of bark, etc.
  - Ask students what measurements are needed to calculate the volumes of trees (height, diameter). The chart they will be using is based on these measurements. Hand the students the board foot table, Student Page , *Tree Volume in Board Feet*. Show the students that across the top are the number of 8 foot logs in the tree. Along the left side are DBHs. Volume is found by determining where the column for # of logs intersects the DBH of the tree. Students will record the sawlog volume of each tree and then add all the volumes to get the total volume of the plot.

- Pulpwood volume is reported in cords. A cord is equal to 128 cubic feet. It can be visualized as a 4' X 4' pile of 8' long sticks. To estimate the number of cords, have the students divide the total number of sticks in each plot by 30. This is an estimate based on an average pulpwood stick of 8" DBH, which equates to about 2.8 ft<sup>3</sup> per stick. A cord of wood contains about 80 ft<sup>3</sup> of solid wood.
2. The students have completed the calculations for each plot. The next step is to utilize that data to calculate averages and then scale the averages up to a per acre basis. Hand each student a copy of Student Page 4, *Data Summary for Fixed Area Plot*. They should enter the information from each of their plots and calculate the averages. When they have completed that step, ask students what the averages tell them (*The averages of the calculations for their plots*). Do you expect them to be the same or similar all the other groups? (*They should be similar if all the plots are in a similar type of forest*). Ask the students how the information they have can be applied to a larger area, such the area in the school forest where they collected the information. What kind of calculation would they need to do? (*They would need to do a calculation to convert their data into information at per area basis, such as per acre.*) Ask them if anyone of them remember how large their plots were (1/50<sup>th</sup> of an acre). How would they convert their per plot data to per acre data? (*Multiply by 50*). Have students do the calculations to convert to per acre. Now they have data that can be shared and compared with other areas of the forest and others forests across the state and world.

#### ACTIVITY 4 – DEVELOPING A CRUISING PROTOCOL

1. In the classroom, explain to students that they will next be conducting a different kind of forest survey. In teams, they will be sampling “variable radius plots.” In variable radius plots, the plot center is identified, but the boundaries are undefined. They will be using a basal area angle gauge to determine which trees are in the plot and which trees are out and to estimate basal area. By holding the angle gauge at plot center and rotating 360 degrees, all of the trees in the plot are identified with the gauge. Each “in” tree’s DBH and sawlog and pulpwood heights is measured. This type of sampling is the most common way that foresters inventory the forest. Demonstrate to the students how to use the angle gauge. Describe how the trees that are larger than the gauge are counted “in” while those trees that are smaller than the gauge are counted “out” (borderline trees are alternated between in and out). Explain that the angle gauge is based on sighting angles and that trees are sampled based on their ratio of DBH to distance (the larger the DBH, the farther away a tree can be counted in). Sampled trees represent a proportional number of the same size trees on a per acre basis. **NOTE:** a basal area prism can be used the same way as an angle gauge.
  2. Hand each student 1 Kruzer tally sheet, the species code sheet, and the instruction sheet that you have printed from the Kruzer program. Review them with the students. Note: To get your copy of the Kruzer program, send an email to leaf@uwsp.edu.
- Top information: Use a plat book or your fGIS map to determine the section-town-range coordinates (can be done in the classroom). Cruiser is the group members. BAF is the basal area factor of your angle gauge – 10. The stand is the area of the forest you are inventorying; give it whatever name you want. Each group will be collecting at two points.



- On the Kruzer tally sheet, there are 6 columns.
  - Sample point (Groups can label their points by their plot number 1 or 2.)
  - Species (Use the code sheet.)
  - DBH
  - Saw sticks (the number of 8' sawlog sticks – remember the DBH and top limits for sawlogs)
  - Total sticks (Add the number of pulpwood sticks to saw sticks to get total sticks.)
  - UpDOB (The UpDOB is the diameter of the first pulpwood stick 4 ½ feet above the top of the sawlog portion. This needs to be estimated.)
- The trees that are measured are those trees that are determined to be “in” by the angle gauge. Data needs to be entered in such a way that each inventory plot can be distinguished. The tables on the far right side are not necessary for this cruise.

**Kruzer 2003**

WADNR Version 2.0 written by Kris Winne

Landowner's Name: \_\_\_\_\_ Town: \_\_\_\_\_ Section-Town-Range: \_\_\_\_\_  
 County: \_\_\_\_\_ Date: \_\_\_\_\_  
 Cruiser: \_\_\_\_\_  
 BAF: 10  
 Stand: NW 1/4  
 #Points: 2

Sample Point	Species	DBH	Saw Sticks	Total Sticks	Up DOB	Species	DBH	Saw Sticks	Total Sticks	Up DOB	Sample Point	Species
1	MR	16		2		MR	5					
	MR	15	2	8	10	MS	6		1			
	MS	17	3	9	10	MS	18		1			
	MS	2				BY	5					
	PW	18	5	10	9	BA	18	4	7	10		
2	MR	6		2		MR	17	3	9	10		
	MR	16	2	8	10	MS	6		1			
	MS	2				PW	20	5	10	9		
	BY	8		3								

- In groups, students will develop a protocol to collect the information they know they need. (As an alternative, students can use Teacher Page 2, *Considerations for Developing a Timber Cruise* as their protocol.) They should determine where the cruise will be done, how the area is to be sampled, and how each piece of information will be collected. If possible, this would be a good time to bring in a forester to share with the students how s/he conducts inventories. If not possible, assign one group developing the sampling procedure to talk with a forester to get some key considerations when developing the sampling procedure. Assign groups to research and develop the protocols for each of the aspects of : 1) selecting a sample method (how many survey points and how those are determined) 2) determining an area in the school forest to be sampled and identifying the boundaries of an area approximately 10 acres, and 3) making the necessary tree measurements (log height, pulpwood height, dbh). More than one group will be working on each protocol. After some independent group work, the groups' ideas should be shared to develop one protocol for each aspect.
- Share and discuss the cruising protocol the student groups have developed. Ensure that everyone has the necessary information to conduct the survey. Refer to Teacher Page 2, *Considerations for Developing a Timber Cruise* for guidance.

**ACTIVITY 5 – KRUZER CRUISING**

- Divide the students into groups of four. Hand each group 1 Kruzer tally sheet, the species code sheet, and the instruction sheet. Review them with the students.
- Follow the protocol that the students have developed or use Teacher Page 2, *Considerations for Developing a Timber Cruise* and conduct the cruise at your field site. Have the groups responsible for each component of the cruise (area, sampling method, and measurements) review their procedures and distribute the necessary equipment to each group.

## ACTIVITY 6 – KRUZER SOFTWARE

- Upon returning to the classroom, show the students the Kruzer spreadsheet using a computer projector and review the components of the spreadsheet.
- Have students enter their team cruise data into the Kruzer spreadsheet. A copy of the spreadsheet can be loaded onto individual or team computers. Have students fill out the top information. The most critical information in the top data are the BAF (10) and # points. If these are inaccurate, all the results will be inaccurate. Then have the teams enter their species code, DBH, saw (the number of 8' saw logs), total (total number of sticks = number of 8' saw logs + number of 8' pulp sticks), and UpDOB (diameter of the first pulp stick 4 ½' above the top of the saw log).
- When they have entered all their data, have students select the "view/print output" tab at the top of the window. This will take them to a summary sheet (See Table 1 on this page for an example.) Have students review their "Species Table – per acre" table on the left side of the page. Does it make sense with what they collected? Are there species of trees with data for which they did not collect? If so, a data entry error was made. Is the basal area for each species and total basal area what they collected (each tree counted "in" = 10 ft<sup>2</sup> basal area/acre)? If not, recheck the data entry form. If there are inaccuracies, have students check their data and go back to the entry window by closing the "output" window.
- Look at the "Sample Tree Information" table. (See Table 2 on this page for an example.) Check to make sure that the "#tallied" the total number of trees that were tallied for all of the plots. If there are inaccuracies, have students check their data and go back to the entry window by closing the "output" window.

Species	#Trees	BA	MBF	Cords
Ash-black	0	0	0.00	0.0
Ash-green	0	0	0.00	0.0
Ash-white	0	0	0.00	0.0
Aspen-big tooth	0	0	0.00	0.0
Aspen-quaking	0	0	0.00	0.0
Basswood	47	20	0.89	3.7
Beech	0	0	0.00	0.0
Birch-river	0	0	0.00	0.0
Birch-white	0	0	0.00	0.0
Birch-yellow	51	10	0.00	1.0
Black locust	0	0	0.00	0.0
Box elder	0	0	0.00	0.0
Buttemut	0	0	0.00	0.0
Cherry-black	0	0	0.00	0.0
Cottonwood	0	0	0.00	0.0
Elm-american	0	0	0.00	0.0
Elm-rock	0	0	0.00	0.0
Elm-slippy	0	0	0.00	0.0
Hackberry	0	0	0.00	0.0
Hickory-Bittamut	0	0	0.00	0.0
Hickory-Shagbark	0	0	0.00	0.0
Ironwood	0	0	0.00	0.0
Maple-hard	0	0	0.00	0.0
Maple-red	444	45	0.67	3.2
Maple-silver	606	40	0.93	3.8
Misc-hardwood	0	0	0.00	0.0
Oak-black	0	0	0.00	0.0
Oak-bur	0	0	0.00	0.0
Oak-N. red	0	0	0.00	0.0
Oak-pin	0	0	0.00	0.0
Oak-swamp white	0	0	0.00	0.0
Oak-white	0	0	0.00	0.0
Walnut-black	0	0	0.00	0.0
Willow	0	0	0.00	0.0
Balsam fir	0	0	0.00	0.0
Cedar-red	0	0	0.00	0.0
Cedar-white	0	0	0.00	0.0
Hemlock	0	0	0.00	0.0
Larch	0	0	0.00	0.0
Misc-conifer	0	0	0.00	0.0
Pine-jack	0	0	0.00	0.0
Pine-red	0	0	0.00	0.0
Pine-scotch	0	0	0.00	0.0
Pine-white	5	10	1.42	0.7
Spruce-black	0	0	0.00	0.0
Spruce-nonway	0	0	0.00	0.0
Spruce-white	0	0	0.00	0.0
Tamarack	0	0	0.00	0.0
<b>Total</b>	<b>1153</b>	<b>125</b>	<b>3.91</b>	<b>12.1</b>

Table 1: Sample Species Table – per acre

Product	#Tallied	Mean DBH	Mean Sawlogs (8')	Mean Pulp Sticks (8')
Cull	0			
PremERCHANTable	8	3.5		0.0
Pulpwood	9	8.1		2.8
Small Sawtimber	1	12.0	2.0	4.0
Large Sawtimber	7	17.3	3.4	5.3
Composite	25	9.4		

Table 2: Example Sample Tree Information

5.

Next look at the “#Trees” column in “Species Table – per acre,” “Stand Table – per acre,” and “Stand Information” tables. (See Tables 3 and 4 on this page for examples.) Did they count that many trees? (*No*). Explain that the inventory they just conducted was a variable radius plot survey. Each tree sampled by the angle gauge represents a proportional number of trees of that size on a per acre basis. Each small tree sampled represents more trees than a larger tree sampled. The “#Trees” is the estimation for the number of trees/acre of each species, product type, and DBH in the area sampled.

Stand Table - per acre				
DBH	#Trees	BA	MBF	Cords
2	688	15	0.00	0.0
4	159	10	0.00	0.0
6	212	35	0.00	2.2
8	52	15	0.00	3.5
10	11	5	0.00	1.5
12	6	5	0.30	0.8
14	0	0	0.00	0.0
16	8	10	0.67	1.4
18	15	25	2.21	2.3
20	2	5	0.73	0.3
22	0	0	0.00	0.0
24	0	0	0.00	0.0
26	0	0	0.00	0.0
28	0	0	0.00	0.0
30	0	0	0.00	0.0
<b>Total</b>	<b>1153</b>	<b>125</b>	<b>3.91</b>	<b>12.1</b>

Table 3: Example Stand Table – per acre

- Ask the students what information can be gathered from the “Species Table.” (*The presence and relative abundance of different tree species.*)

Stand Information									
Product	Trees Per Acre	BA Per Acre	Mean DBH (in.)	Cords Per Acre	MBF Per Acre	Cords			
						Per Sq.Ft. BA	MBF Per Sq.Ft. BA	Cords Per Tree	MBF Per Tree
Cull	0	0	0.0						
PremERCHANTABLE	957	40	2.8						
Pulpwood	168	45	7.0	7.8		0.169		0.046	
Small Sawtimber	6	5	12.0	0.8	0.30	0.169	0.060	0.133	0.047
Large Sawtimber	22	35	17.1	3.6	3.61	0.103	0.103	0.165	0.164
Composite	1153	125	4.5	12.1	3.91				

Table 4: Example Stand Information

- Have students look at the “Stand Information” and “Stand Table – per acre” tables. What additional knowledge can be learned from these tables? (*The “Stand Information” table provides information about product volumes. The “Stand Table” provides the distribution of trees, basal area, and product volumes by diameter.*) How are these useful? (*Amount of forest products that can be produced from the forest, the distribution of sizes can provide information about the age and future condition of the forest.*)
- Have students save their spreadsheet to their hard drive using their group members’ initials.
- Each group inventoried two plots. Are all the groups’ data the same? (*Most likely not.*) In sampling, the more samples that are taken, the more accurate the data tends to be. Therefore, to get a more accurate picture of the forest, it would be important to combine the groups’ inventory data. The students will use the summary data in the final activity in the lesson to describe the forest and consider some basic management recommendations. Assign one student from each group to transfer their group’s data into one master spreadsheet.

### CONCLUSION – UTILIZING THE KRUZER DATA

- Utilizing the Kruzer output data, students will describe their forest. Print out a copy of the Kruzer “output” sheet of the class data for each student. As a class, have them compare the class data to their team’s data. Do they notice any trends?

- The next step is to utilize the data from their cruise to describe their forest. Utilizing Student Page *5*, *Kruzer Data Summary*, have the students summarize the data for the forest. You will need to explain the forest type and stocking situation. Give each student access to an electronic copy of Student Pages *6A-O*, *Forest Types and Stocking Charts* or hand out paper copies of the pages.
- Forest type: Forests can be described by the species of trees that are present. This is called forest type or cover type. The forest type is specified based on the most common trees. Student Page *6A-O*, *Forest Types and Stocking Charts*, contains the most common forest types in Wisconsin. Based on the most common species surveyed and the other species present, the forest type can be identified.
- Stocking: The term stocking indicates the number of trees or amount of basal area per acre in an area of forest. Stocking is a relative term. It compares the existing number of trees or basal area with a density that produces optimum growth. Forests can be fully-stocked, under-stocked, or over-stocked. An over-stocked area contains more trees or basal area than desired. A stocking level that produces maximum yield of forest products is desired for timber production. In some situations, stocking is not applicable. For example, since aspen is harvested by clear-cutting on a rotational basis, stocking doesn't apply to managing this forest type.

- Stocking is determined from stocking charts or tables. Select the stocking chart for the forest type and the correct chart for the average DBH. Locate the basal area on the side of the chart and the number of trees per acre along the bottom. If the lines intersect above the "A" line, the area is over-stocked. If the lines intersect below the "B" line, it is under-stocked. If they intersect between the "A" and "B" lines, the area is fully stocked. Areas that are over-stocked are typically considered for thinning/harvesting. Areas that are under-stocked could be considered for tree planting. Typically, areas that are fully-stocked are left to grow.

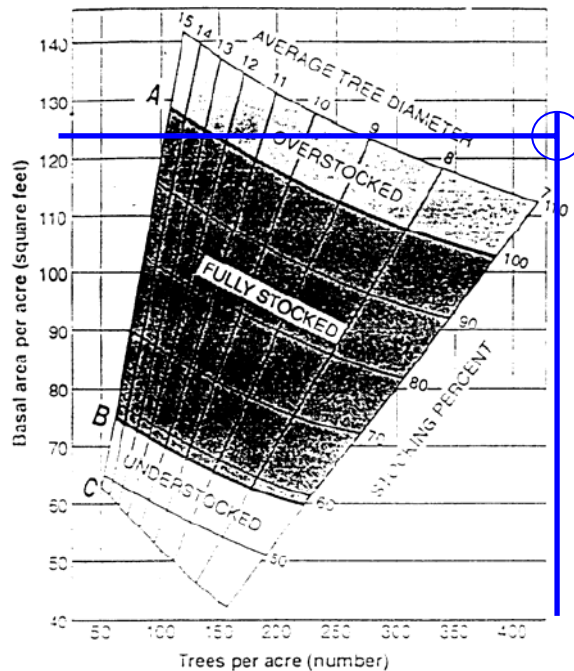

- For example, using the table to the right and the data from above, for a stand with an average diameter of 9.4 inches, a basal area of 125 square feet, and 1153 trees per acre, we can determine that this is an overstocked stand.

- When students have completed Student Page *5*, *Kruzer Data Summary*, review the results. Ask for volunteers to share their data. Have students discuss differences in what they determined for forest type and stocking level to ensure that everyone understands the process and gets accurate conclusions.

## SUMMATIVE ASSESSMENT – KRUZER REPORT

Have students write a summary paper based on the data from the Kruzer inventory. The paper should include the methods and tools used, the information collected (including definitions), the results of the inventory (number of trees, basal area, volumes), the description of the area (forest type), and the management recommendation (planting, leave alone, harvest). The paper should also provide an opportunity to recommend how to improve the data collection process, i.e., what would be done during the next timber cruise.

## EXTENSION

- 1) Invite a forester into your classroom to talk about how they conduct a forest inventory. This can be done before the cruise, and can be used to help students understand how to conduct the inventory. If it is done after the cruise, students could present their methods and data to the forester for feedback.
- 2) Conduct additional inventories (cruises) in other sections of the forest or other forests to make comparisons between the areas.
- 3) Have students make their own tree scale sticks (see LEAF Lesson Guide 5/6, Field Enhancement 1, Wood's Worth) or angle gauge (see <http://forestry.about.com/library/weekly/aa121398.htm>)

## RECOMMENDED RESOURCES

A True Picture: Taking Inventory of Your Woodlot. Eastern Ontario Model Forest. Available for download or purchase at:

[www.eomf.on.ca/publications/publications\\_details\\_e.aspx?pubno=37](http://www.eomf.on.ca/publications/publications_details_e.aspx?pubno=37)

Estimating the Volume of a Standing Tree Using a Scale (Biltmore) Stick. North Carolina State Cooperative Extension. Available at: <http://www.ces.ncsu.edu/nreos/forest/pdf/WON/won05.pdf>.

Lake States Woodland: Measuring Trees and Estimating Volume. Jeff Martin. Lake States Woodlands. Available at: <http://learningstore.uwex.edu/pdf/G3332.pdf>

Reference Handbook for Foresters. USDA Forest Service. NA-FR-15. Available at: [www.na.fs.fed.us/pubs/refhbk/refhbk.pdf](http://www.na.fs.fed.us/pubs/refhbk/refhbk.pdf)

Wisconsin Woodlands: Assessing Stocking Conditions in Your Timber Stand. Jeff Martin. University of Wisconsin Cooperative Extension. Available at: <http://learningstore.uwex.edu/pdf/G3362.pdf>

## MODEL ACADEMIC STANDARDS

### AGRICULTURE EDUCATION B.12.1

#### *Technology/Information*

**Standard is:** Apply knowledge of technology to identify and solve problems

Use a software program to compile and analyze statistical data and prepare a presentation for a group

Students utilize the Kruzer software program to analyze timber cruise data. Students present results to the class and prepare a written report.

### AGRICULTURE EDUCATION C.12.2

#### *Leadership*

**Standard is:** Practice skills relating to communication, problem-solving, and decision-making through individual, group, and team processes.

Students work in groups to conduct an inventory of the forest. They collaborate to develop a timber cruise protocol. Individuals play different roles in the team to collect and analyze information collected.

### AGRICULTURE EDUCATION D.12.4

#### *Agriscience/production*

**Standard is:** Explore traditional and nontraditional food, fiber, and ornamental horticultural jobs/careers and identify necessary skills, aptitudes, and abilities.

Students learn some of the skills and aptitudes foresters use by conducting an inventory of the school forest.



### MATHEMATICS A.12.5

#### *Mathematical Processes*

**Standard is:** Organize work and present mathematical procedures and results clearly, systematically, succinctly, and correctly.

Students create a written report utilizing the timber cruise procedures and data.

### MATHEMATICS B.12.5

#### *Number Operations and Relationships*

**Standard is:** Create and critically evaluate numerical arguments presented in a variety of classroom and real-world situations (e.g., political, economic, scientific, social)

Students utilize the timber cruise data to determine the forest type classification of their forest plot.

Students discuss differences in interpretation of the information to come to consensus on a classification.

### MATHEMATICS D.12.1

#### *Measurement*

**Standard is:** Identify, describe, and use derived attributes (e.g., density, speed, acceleration, pressure) to represent and solve problem situations

Students utilize and describe volume and basal area data of a forest plot to determine the stocking condition of the forest and to make suggest management recommendations for the forest.

### MATHEMATICS D.12.3

#### *Measurement*

**Standard is:** Determine measurements indirectly, using

- estimation

Students estimate the diameter and number of pulpwood sticks above the saw-log component of trees surveyed during the timber cruise.

### MATHEMATICS E.12.1

#### *Statistics and Probability*

**Standard is:** Work with data in the context of real-world situations by

- Formulating hypotheses that lead to collection and analysis of one- and two-variable data
- Designing data collection plan that considers random sampling, control groups, the role of assumptions, etc.
- Conducting an investigation based on that plan
- Using technology to generate displays, summary statistics, and presentations

Students develop and implement a timber cruise data collection protocol that includes determination of area to be sampled, selection of random plots, and data collection tools and methods. Students analyze the information collected using Kruzer software (an Excel spreadsheet). Students create a written report detailing the protocol and results.

### SCIENCE C.12.3

#### *Science Inquiry*

**Standard is:** Evaluate the data collected during an investigation, critique the data-collection procedures and results, and suggest ways to make any needed improvement

Students develop and implement a timber cruise data collection protocol and analyze the data collected. In their written report, students will make recommendations to improve the effectiveness of the timber cruise procedure.

### SCIENCE H.12.7

#### *Science in Social and Personal Perspectives*



**Standard is:** When making decisions, construct a plan that includes the use of current scientific knowledge and scientific reasoning  
Students utilize the data collected during the timber cruise and forestry resources to make forest management recommendations for the area of their inventory.

## **MULTIPLE INTELLIGENCES**

Verbal-Linguistic  
Logical-Mathematical  
Visual-Spatial  
Intrapersonal  
Naturalistic

## Forest Measurement Calculations Key

### Tree Volume

Simplified formula for calculating tree volume is the formula for the volume of a frustum of a cone is:

$$V = \frac{\pi h}{12}(D^2 + Dd + d^2)$$

V = Volume in board feet

$\pi$  = pi = 3.14

h = merchantable height in feet

D = diameter at bottom in feet

d = diameter at top in feet

### Steps

Use Figure 1 to determine the needed information.

1. Enter height in feet

h = 16

2. Convert diameter in inches into diameter in feet.

D = 12 inches    D/12 = 1 feet

d = 6 inches    d/12 = .5 feet

3. Calculate diameter in feet squared

D<sup>2</sup> = 1 ft<sup>2</sup>

d<sup>2</sup> = .25 ft<sup>2</sup>

4. Multiply D and d

Dd = .5

5. Enter the numbers in the formula and calculate to get the volume in ft<sup>3</sup>

$$V = \frac{\pi h}{12}(D^2 + Dd + d^2) = \underline{7.33} \text{ ft}^3$$

6. Convert volume in cubic feet to board feet.

1 board foot = 0.0833 ft<sup>3</sup>

V in board feet = V in ft<sup>3</sup>/0.0833 ft<sup>3</sup> = 88 board feet

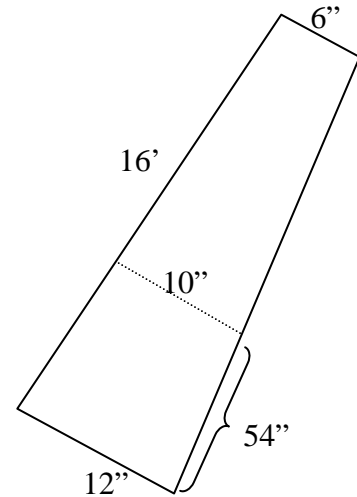

Figure 1: frustum of a cone which approximately represents the shape of a tree

### Basal area

Formula for calculating basal area of tree (BA) is the formula for the area of a circle:  $BA = \pi r^2$  or

$$BA = \pi \left(\frac{DBH}{2}\right)^2$$

DBH = diameter at breast height in feet (54" from ground)

$\pi$  = pi = 3.14

### Steps

1. Convert diameter in inches to diameter in feet.

$\frac{DBH}{12} = \underline{.83}$  diameter in feet

2. Convert diameter in feet to radius in feet.

radius =  $\frac{DBH}{2} = \underline{.42}$  ft

3. Find the radius in feet squared.

r<sup>2</sup> = (r)(r) = .18 ft<sup>2</sup>

4. Multiply  $\pi$  by radius in feet squared to calculate basal area in feet squared.

BA =  $\pi r^2 = \underline{.56}$  ft<sup>2</sup>

## CONSIDERATIONS FOR DEVELOPING A TIMBER CRUISE

### Location

- Selecting an area that is similar across the area will make the data easier to use, but it's not necessary.
- Select an area that is dry enough to access.
- Select an area that has enough space to avoid students going on adjoining lands

### Sampling Procedure

Foresters typically aim to have one sample plot per acre of forest being inventoried. To get representative data, the plots should be spread throughout the area being sampled. A way to do this is to set up parallel transect lines across the area or to sample at different distances along compass lines beginning in the center of the area sampled. For example: if each group will be inventorying 2 plots, assign the teams directions and have them write down the location of their plots relative to the center of the area (where you gathered):

North – 40' and 300'

Northeast – 310' and 200'

East – 100' and 180'

Southeast – 150' and 300'

South – 270' and 50'

Southwest – 300' and 200'

West – 160' and 90'

Northwest – 200' and 350'

### Forest Measurements

Providing the following tips when making the measurements will help the students collect good data:

- Mark the plot center by digging a small hole or using a small piece of toilet paper
- Mark the direction or tree where the cruise is started to avoid confusion (always start directly north, for example)
- All trees determined "in" by the angle gauge need to be tallied. If under 6" DBH, they are still tallied but there are no sticks (not merchantable)
- All measurers should be working on the same tree to avoid confusion

The UpDOB measurement is a challenging one. It needs to be guessed, but the guess needs to be based in common sense, i.e., if the end of a sawlog is 8" in diameter, likely the UpDOB will be 7" or 8".

The number of sticks or logs is best measured with the tree scale stick. However, after some practice students may be able to estimate these accurately.

### Equipment

The following equipment will likely be needed to conduct the cruise:

- clipboards
- angle gauges
- tree scale sticks (height and diameter)
- compasses
- tape measures

## Forest Measurement Calculations

### Tree Volume

Simplified formula for calculating tree volume is the formula for the volume of a frustum of a cone is:

$$V = \frac{\pi h}{12}(D^2 + Dd + d^2)$$

V = Volume in board feet

$\pi$  = pi = 3.14

h = merchantable height in feet

D = diameter at bottom in feet

d = diameter at top in feet

#### Steps

Use Figure 1 to determine the needed information.

1. Enter height in feet

h = \_\_\_\_\_

2. Convert diameter in inches into diameter in feet.

D = \_\_\_\_\_ inches    D/12 = \_\_\_\_\_ feet

d = \_\_\_\_\_ inches    d/12 = \_\_\_\_\_ feet

3. Calculate diameter in feet squared

$D^2 =$  \_\_\_\_\_  $\text{ft}^2$

$d^2 =$  \_\_\_\_\_  $\text{ft}^2$

4. Multiply D and d

Dd = \_\_\_\_\_

5. Enter the numbers in the formula and calculate to get the volume in  $\text{ft}^3$

$$V = \frac{\pi h}{12}(D^2 + Dd + d^2) = \text{_____ } \text{ft}^3$$

6. Convert volume in cubic feet to board feet.

1 board foot = 0.0833  $\text{ft}^3$

V in board feet = V in  $\text{ft}^3 / 0.0833 \text{ft}^3 =$  \_\_\_\_\_ board feet

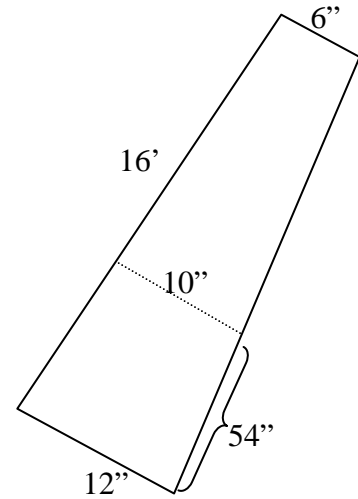

Figure 1: frustum of a cone which approximately represents the shape of a tree

### Basal area

Formula for calculating basal area of tree (BA) is the formula for the area of a circle:  $BA = \pi r^2$  or

$$BA = \pi \left( \frac{DBH}{2} \right)^2$$

DBH = diameter at breast height in feet (54" from ground)

$\pi$  = pi = 3.14

#### Steps

1. Convert diameter in inches to diameter in feet.

$\frac{DBH}{12} =$  \_\_\_\_\_ diameter in feet

2. Convert diameter in feet to radius in feet.

radius =  $\frac{DBH}{2} =$  \_\_\_\_\_ ft

3. Find the radius in feet squared.

$r^2 = (r)(r) =$  \_\_\_\_\_  $\text{ft}^2$

4. Multiply  $\pi$  by radius in feet squared to calculate basal area in feet squared.

$BA = \pi r^2 =$  \_\_\_\_\_  $\text{ft}^2$

## FIXED AREA PLOT DATA

Team members: \_\_\_\_\_

Date: \_\_\_\_\_ Plot number: \_\_\_\_\_

Area of plot: \_\_\_\_\_ acre Radius of plot: \_\_\_\_\_ feet

Tree #	Species	DBH (inches)	# of 8' Saw Logs	# of 8' Pulp Sticks	Basal area (feet <sup>2</sup> )	Sawlog volume (board feet)
1						
2						
3						
4						
5						
6						
7						
8						
9						
10						
11						
12						
13						
14						
15						
<b>Totals</b>						
<b>Pulpwood cords</b>						

### Explanation of measurements

- DBH = diameter of the tree 4 ½ feet above the ground
- # of Saw logs: Broadleaf trees - 11 inches is the minimum DBH and 10 inches is the minimum diameter at the small end (top); Conifer trees - 9 inches is the minimum DBH and 8 inches is the minimum diameter at the small end.
- # pulpwood sticks - 6 inches is the minimum DBH and 4 inches is the minimum diameter at the small end for all species.
- Forked, rotten, split, and excessively crooked trunks are not merchantable.

### Calculations

- Basal area calculation =  $\pi r^2$
- Sawlog volume determination – use the board foot table to determine saw log volume.
- Pulpwood volume estimate – divide the total number of sticks by 30 to get an estimate of the number of cords

## TREE VOLUME IN BOARD FEET

### Scribner Rule

DBH (inches)	Number of 8 foot logs							
	1	2	3	4	5	6	7	8
9	13	23						
10	17	30	40					
11	22	38	51	62				
12	28	48	66	78	89	100		
13	34	59	81	96	112	126	138	145
14	40	70	96	116	141	160	170	178
15	47	81	113	137	166	188	204	220
16	54	93	129	158	191	224	248	263
17	63	106	148	182	218	257	285	308
18	72	122	168	207	248	292	325	355
19	81	137	190	234	280	328	368	405
20	90	156	212	262	317	366	415	450
21	100	173	238	293	351	405	460	595
22	111	194	262	328	392	450	510	610
23	123	215	290	360	435	500	560	620
24	137	236	319	400	470	550	620	690
25	149	258	348	440	520	600	680	760
26	165	281	381	480	565	650	740	820
27	179	305	415	520	620	710	800	890
28	195	331	450	560	670	760	860	960
29	210	356	485	600	720	830	930	1030
30	227	383	520	650	770	890	1000	1110
31	245	410	560	700	830	950	1080	1200
32	260	440	600	740	890	1020	1150	1280
33	279	470	640	790	950	1080	1230	1370
34	294	500	680	840	1010	1160	1300	1460
35	312	530	720	900	1080	1230	1390	1560
36	330	565	770	960	1140	1310	1480	1650

(From Geveorkiantz, SR and Olsen, LP. 1955, in "Measuring Tees and Estimating Volume" Martin, J. Lake States Woodlands.)



## DATA SUMMARY FOR FIXED AREA PLOT

Team members: \_\_\_\_\_

Date: \_\_\_\_\_ Plot size: \_\_\_\_\_ acre

### Basal area

Basal area from DBH

Basal area of plot #1 \_\_\_\_\_ ft<sup>2</sup>

Basal area of plot #2 \_\_\_\_\_ ft<sup>2</sup>

Basal area of plot #3 \_\_\_\_\_ ft<sup>2</sup>

Basal area of plot #4 \_\_\_\_\_ ft<sup>2</sup>

Average basal area/plot = \_\_\_\_\_ ft<sup>2</sup>

Basal area/acre = \_\_\_\_\_ ft<sup>2</sup>

### Sawlog Volume

Sawlog volume of plot #1 \_\_\_\_\_ board feet

Sawlog volume of plot #2 \_\_\_\_\_ board feet

Sawlog volume of plot #3 \_\_\_\_\_ board feet

Sawlog volume of plot #4 \_\_\_\_\_ board feet

Average sawlog volume/plot = \_\_\_\_\_ board feet

Sawlog volume/acre = \_\_\_\_\_ board feet

### Pulpwood Volume

Pulpwood volume of plot #1 \_\_\_\_\_ cords

Pulpwood volume of plot #2 \_\_\_\_\_ cords

Pulpwood volume of plot #3 \_\_\_\_\_ cords

Pulpwood volume of plot #4 \_\_\_\_\_ cords

Average pulpwood volume/plot = \_\_\_\_\_ cords

Pulpwood volume/acre = \_\_\_\_\_ cords



## FOREST TYPE AND STOCKING CHARTS WHITE PINE FOREST

**Forest type composition:** More than 50 percent of basal area in pine with white pine predominant.

**Associated Species:** red pine, jack pine, aspen, white birch, red maple, red oak, northern pin oak, black oak, white oak, balsam fir, white spruce, and eastern hemlock.

### Stocking Levels for White Pine

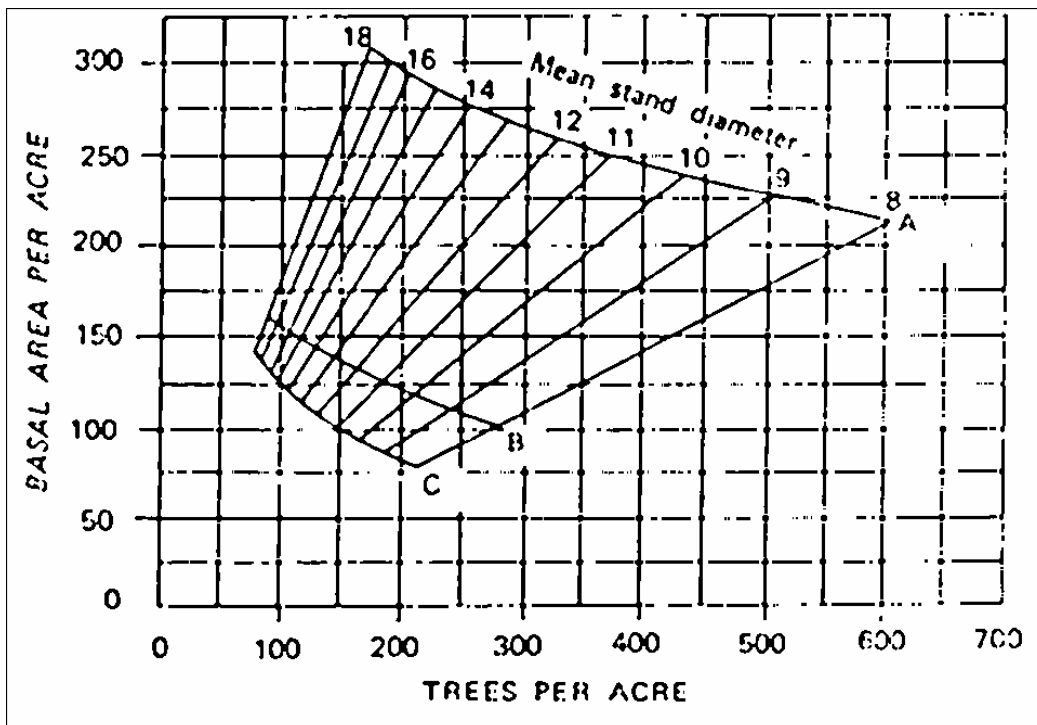
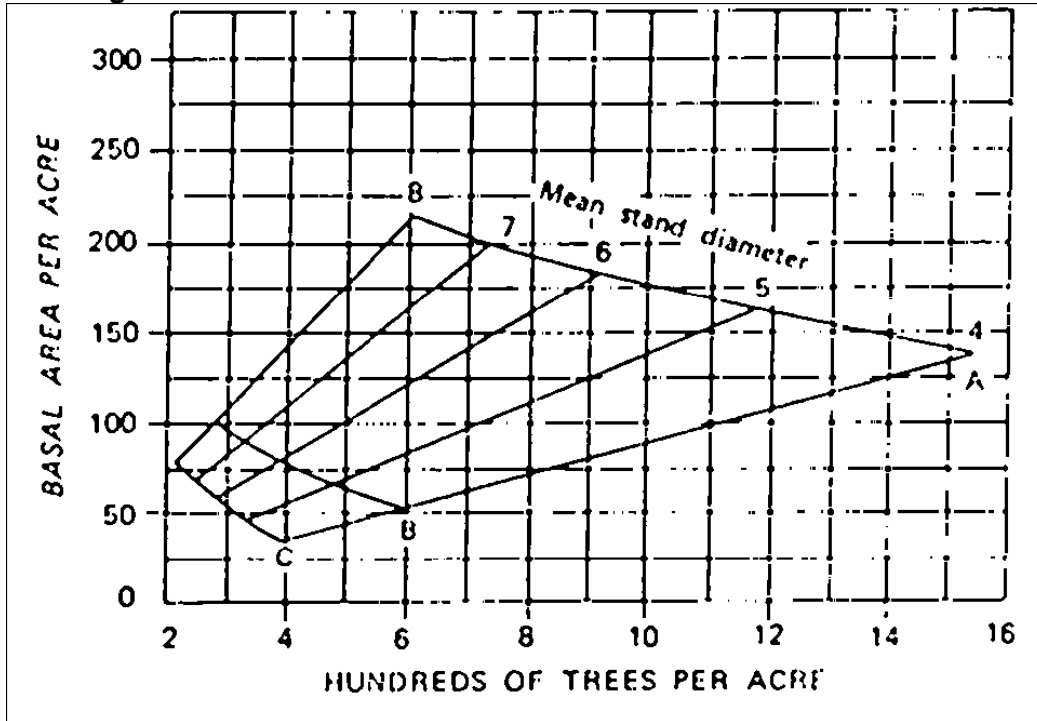

## FOREST TYPE AND STOCKING CHARTS RED PINE FOREST

**Forest type composition:** More than 50 percent pine with red pine predominant.

**Associated Species:**

1. Sandy Soils - Jack pine, white pine, quaking aspen, bigtooth aspen, black oak, red oak, white oak, paper birch, and red maple.
2. Loamy Soils - White pine, black cherry, balsam fir, sugar maple, basswood, yellow birch, white spruce, and eastern hemlock. Natural red pine stands do not occur on these soils. These associates are found only in plantations.

**Stocking Levels for Red Pine**

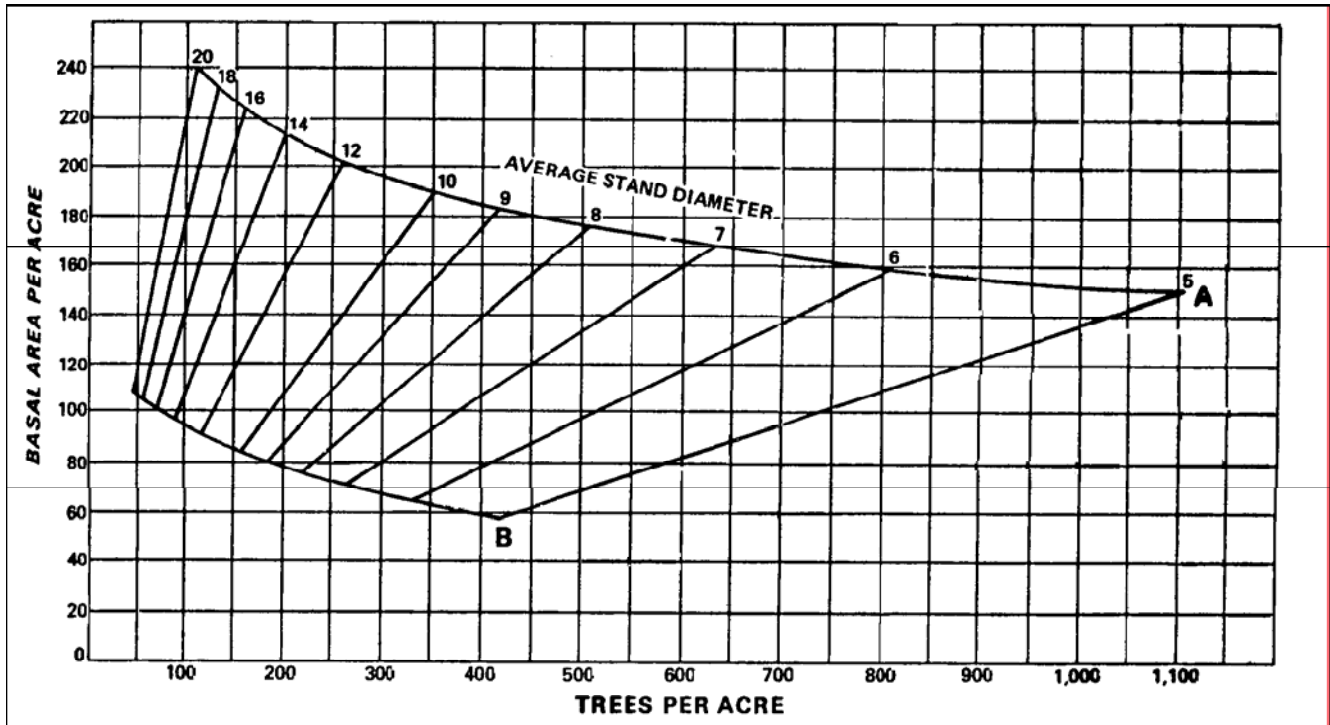

# FOREST TYPE AND STOCKING CHARTS

## JACK PINE FOREST

**Stand Composition:** More than 50 percent pine with jack pine predominant.

**Associated Species:** Common Associates: red pine, white pine, scrub oaks, aspen, white birch;  
Occasional Associates: red maple, black cherry, balsam fir, white spruce

### Stocking Levels for Jack Pine

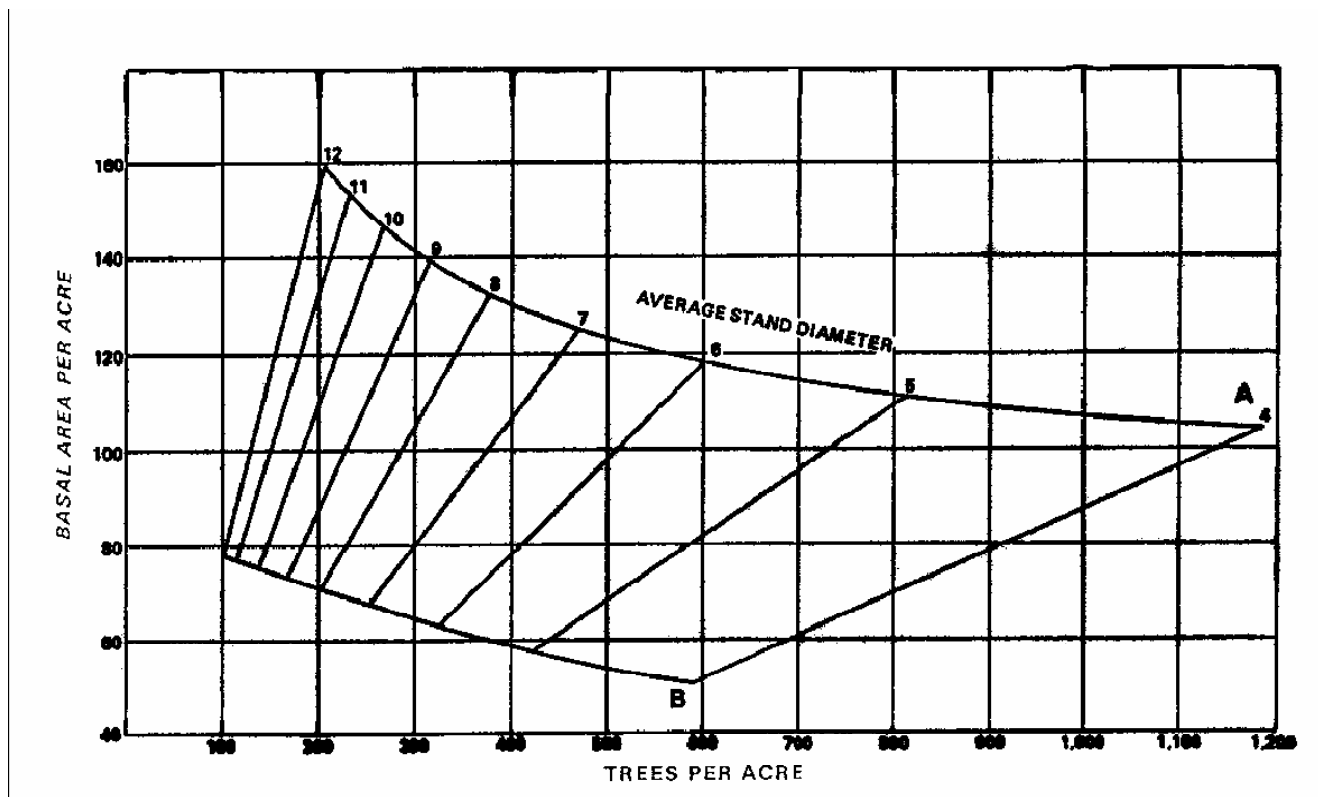

## FOREST TYPE AND STOCKING CHARTS FIR-SPRUCE FOREST

**Stand Composition:** More than 50 percent balsam fir or white spruce or both.

**Associated Species:** Paper birch, trembling aspen, red maple, white cedar, black spruce, hemlock, red pine, white pine, jack pine, and other species found among northern hardwoods and swamp hardwoods.

### Stocking Levels for Fir-Spruce

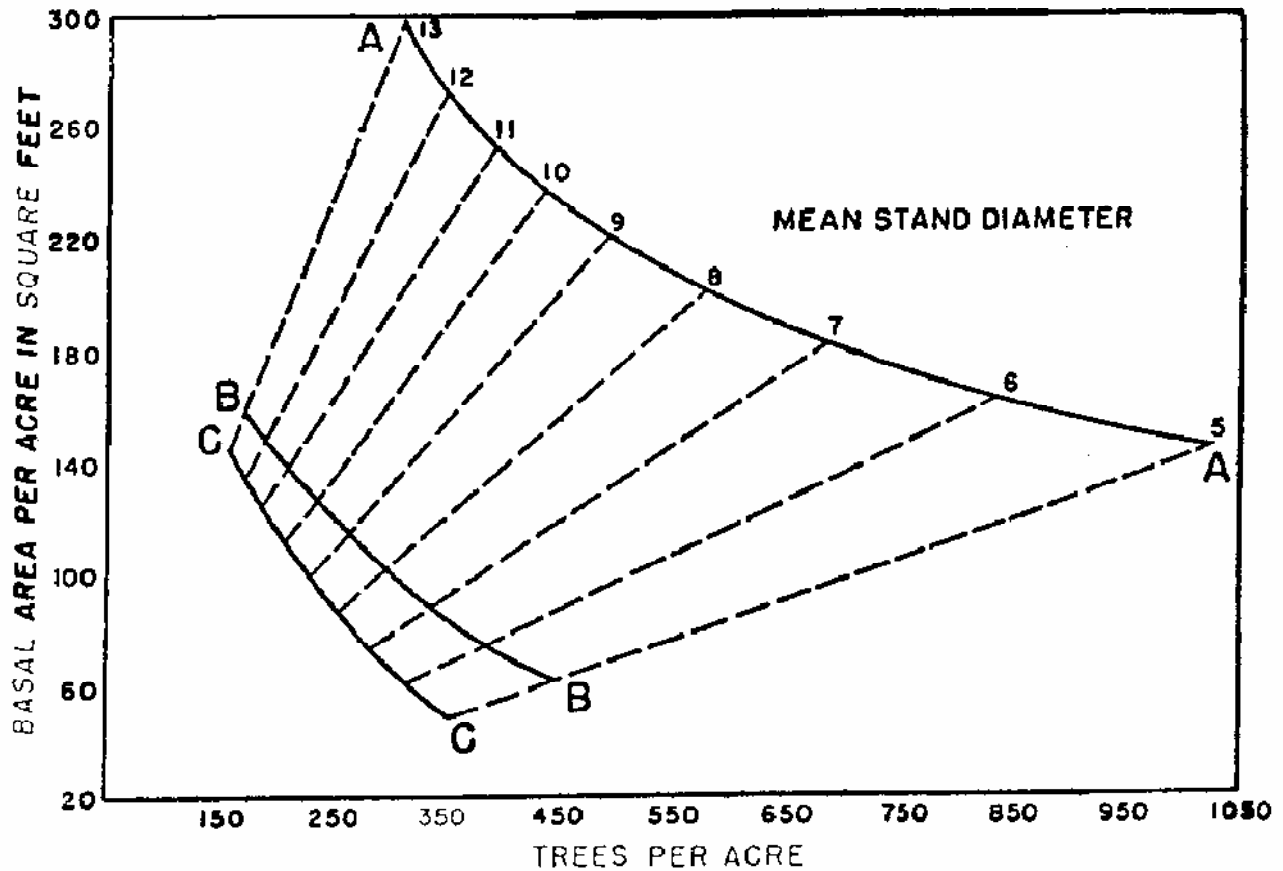



# FOREST TYPE AND STOCKING CHARTS

## SWAMP CONIFER FOREST



### 1) Balsam Fir Forest Type

**Stand Composition:** More than 50 percent swamp conifers with balsam fir predominant.

**Associated Species:** Northern white cedar, black spruce, white spruce, tamarack, hemlock, white pine, jack pine, black ash, paper birch, yellow birch, red maple, quaking aspen, and balsam poplar.

### 2) Tamarack Forest Type

**Stand Composition:** More than 50 percent swamp conifers with tamarack predominant.

**Associated Species:** Organic soils - black spruce, white spruce, and northern white cedar; Mineral soils - quaking aspen, paper birch, red maple, and white pine.

### 3) White Cedar Forest Type and Stocking Charts

**Stand Composition:** More than 50 percent swamp conifers with northern white cedar predominant.

**Associated Species:** black spruce, white spruce, tamarack, balsam fir, eastern hemlock, black ash, red maple, yellow birch, paper birch, American elm, and quaking aspen.

**Stocking Levels for Swamp Conifers** - No stocking charts available for these forest types.

# 6F

## FOREST TYPE AND STOCKING CHARTS HEMLOCK HARDWOOD FOREST

**Stand Composition:** more than 50 percent hemlock eastern hemlock, with yellow birch, eastern white pine, sugar maple, and in the eastern part of the state, American beech.

**Associated Species:** Northern red oak, red maple, basswood, white ash, northern white cedar, paper birch, and balsam fir.

### Stocking Levels for Hemlock Hardwood

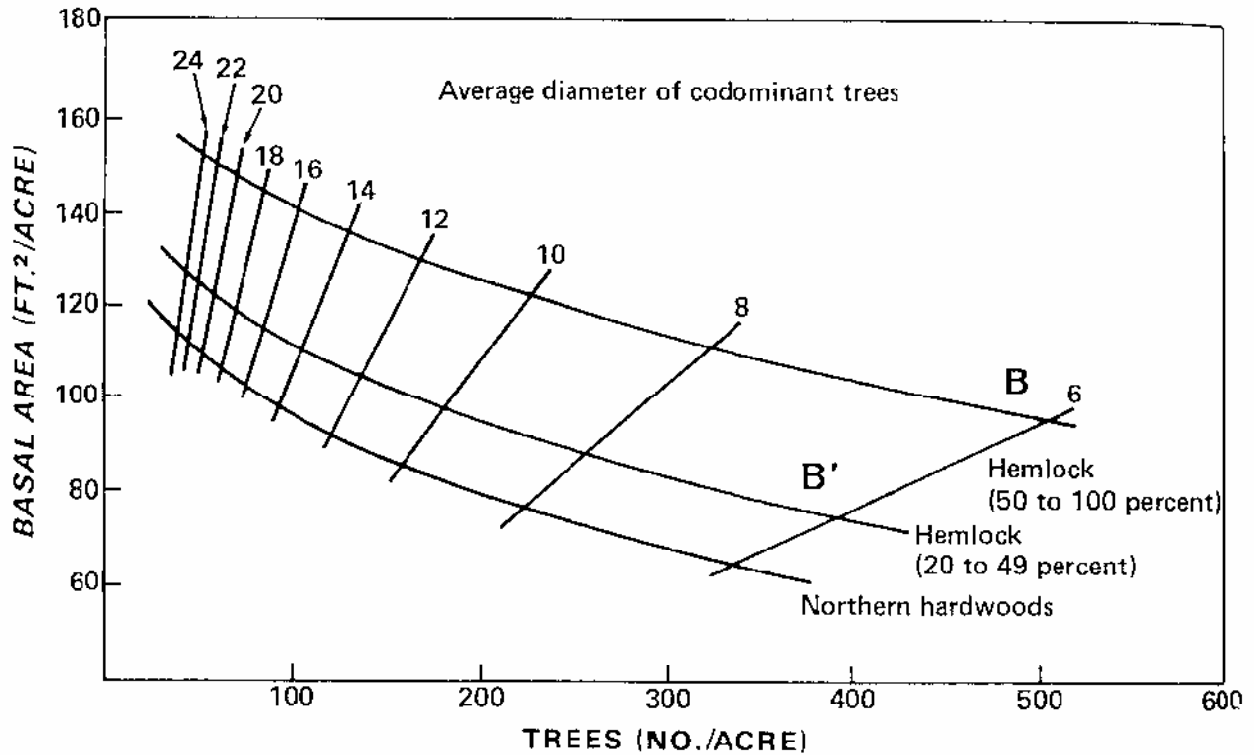

# FOREST TYPE AND STOCKING CHARTS

## NORTHERN HARDWOOD FOREST

**Stand Composition:** Any combination of sugar maple, beech, basswood, white ash, and yellow birch comprises more than 50% of the basal area in sawtimber and poletimber stands or more than 50% of the stems in sapling and seedling stands. Any combination of the five major species can dominate any stand, but typically sugar maple is the predominant overstory species. Occurs throughout Wisconsin, but is most common north of the tension zone.

**Associated Species:** red maple, red oak, hemlock, white pine, and balsam fir.

### Stocking Levels for Northern Hardwoods

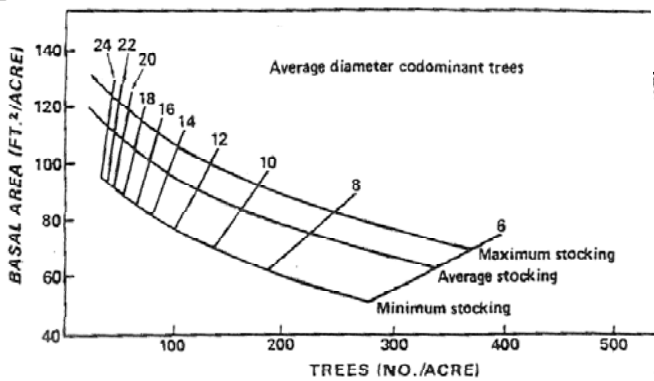

Figure 6.—Stocking levels for northern hardwood stands containing less than 20 percent conifers or basswood by basal area, and number of trees per acre for specified diameter classes.

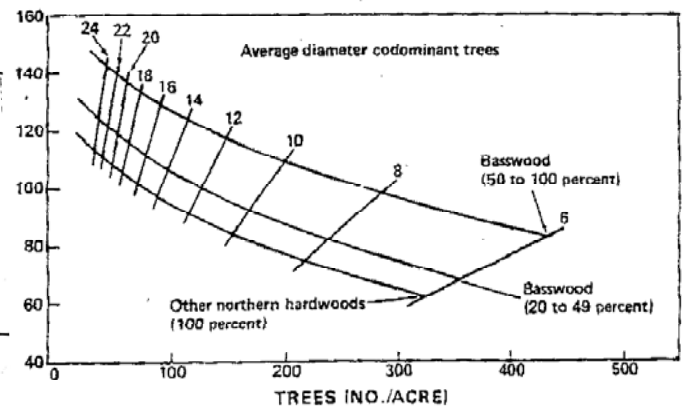

Figure 7.—Stocking levels for even-age northern hardwood basswood stands in the Lake States by basal area and number of trees per acre for specified diameter classes and certain percentages of basswood and other northern hardwoods.

**Table 1.** Stocking guidelines for uneven-aged stands of northern hardwoods, showing the desired number of trees and basal area per acre for trees of different diameters as measured in inches at breast height.

DBH Class (inches)	Desirable Stand After Cutting	
	Trees/Acre (number)	Basal Area/Acre (square feet)
2-4	202	8
5-9	65	16
10-14	28	22
15-19	17	26
20-24	8	20
<b>TOTAL</b>	<b>320</b>	<b>92</b>

(From Wisconsin Woodlands: Estimating Stocking Conditions in Your Timber Stand. Jeff Martin. 1996.)

## FOREST TYPE AND STOCKING CHARTS CENTRAL HARDWOODS FOREST

**Stand Composition:** Contains more than 50% upland hardwood species or type including basswood, red maple, sugar maple, white ash, shagbark hickory, bitternut hickory and elm; and other species including Black walnut, butternut, oaks, and white pine.

No species or type constitutes over 50% of the stand. This forest type would primarily be found south of Wisconsin's Vegetative Tension Zone

**Associated Species:** Aspen, black cherry, box elder, white birch, eastern red cedar, hackberry, and ironwood.

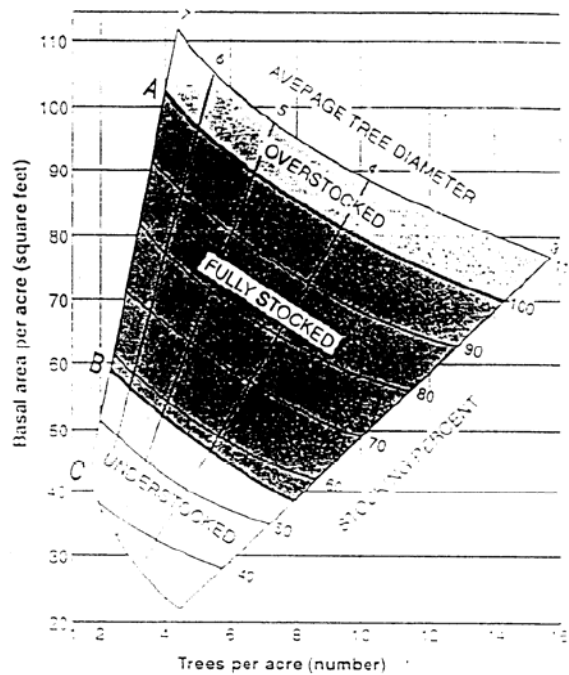
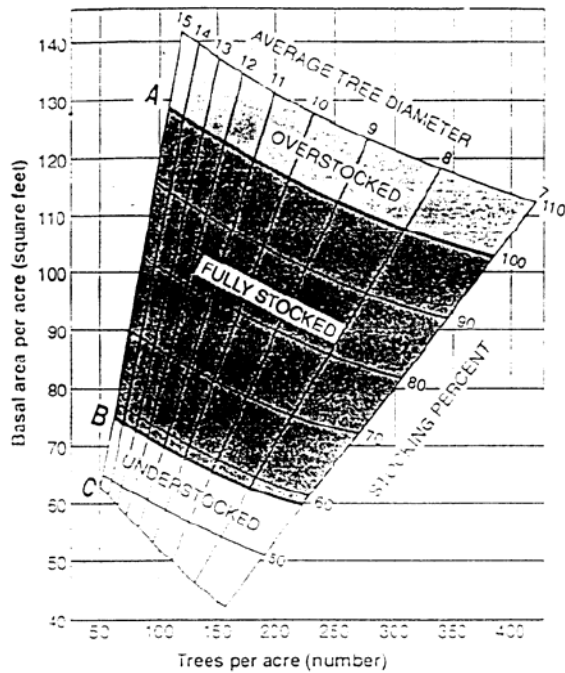

# FOREST TYPE AND STOCKING CHARTS

## OAK FOREST

**Stand Composition:** More than 50 percent of the stand consists of oaks including bur oak, black oak, northern pin oak, white oak and red oak

**Associated species:** basswood, shagbark hickory, black cherry, red maple, black walnut, white pine, aspen, paper birch, sugar maple, ironwood, American elm, American beech, and hemlock.

### Stocking Levels for Oak

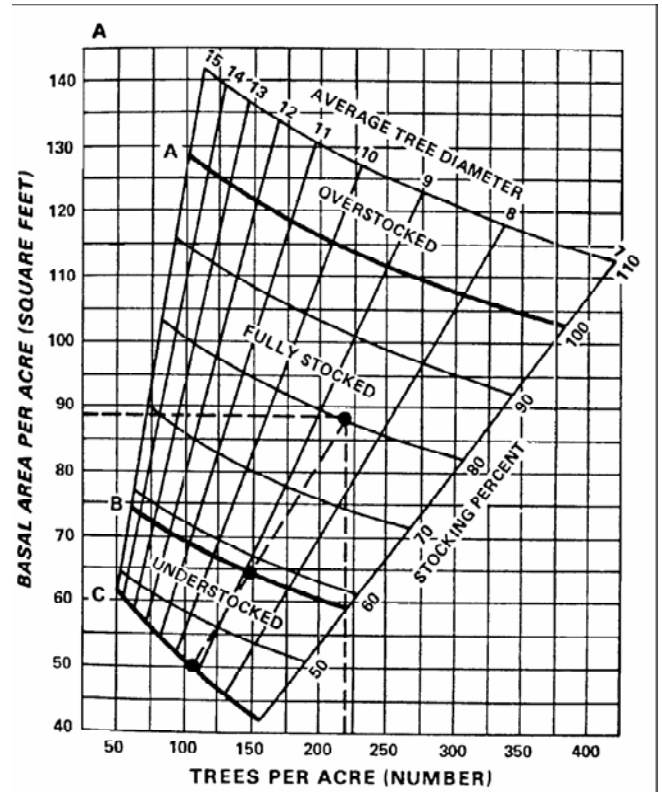
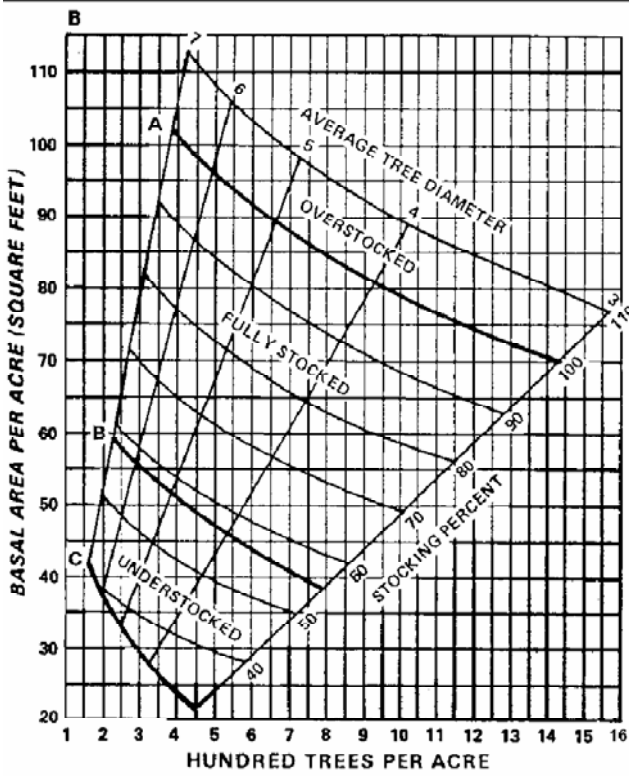



# 6J

## FOREST TYPE AND STOCKING CHARTS PAPER BIRCH FOREST

**Stand Composition:** Paper birch (also called white birch) comprising more than 50 percent of the basal area in sawtimber and pole timber stands, or more than 50 percent of the stems in sapling and seedling stands.

**Associated Species:** aspen, balsam fir, jack pine, red oak, sugar maple, white spruce, yellow birch, and American beech.

### Stocking Levels for Paper Birch

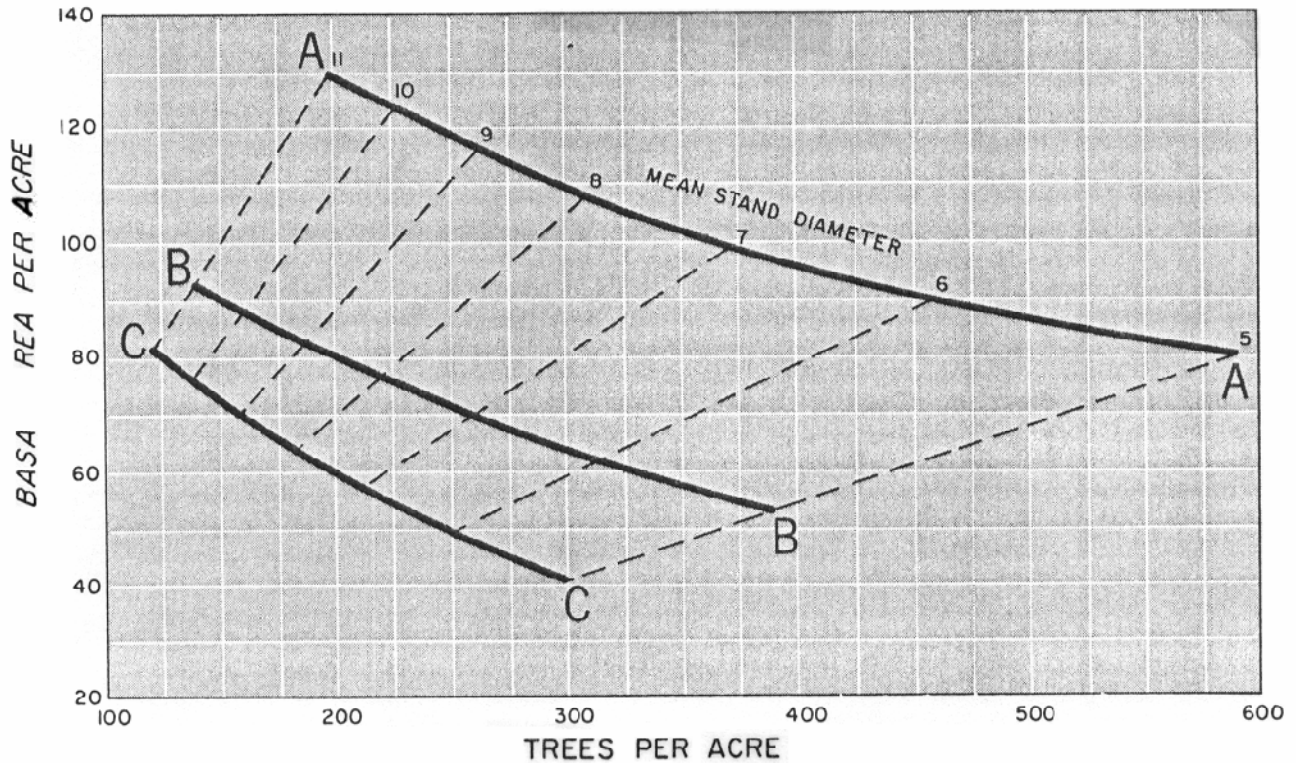

## FOREST TYPE AND STOCKING CHARTS BLACK WALNUT FOREST

**Stand Composition:** At least 50 percent **black walnut**. However, it is present in southern Wisconsin to a very limited extent and is seldom abundant.

**Associated Species:** Eastern red cedar, white oak, red oak, shagbark hickory, American beech, sugar maple, white ash, black cherry, basswood, American elm, hackberry, boxelder, and green ash

### Stocking Levels for Black Walnut

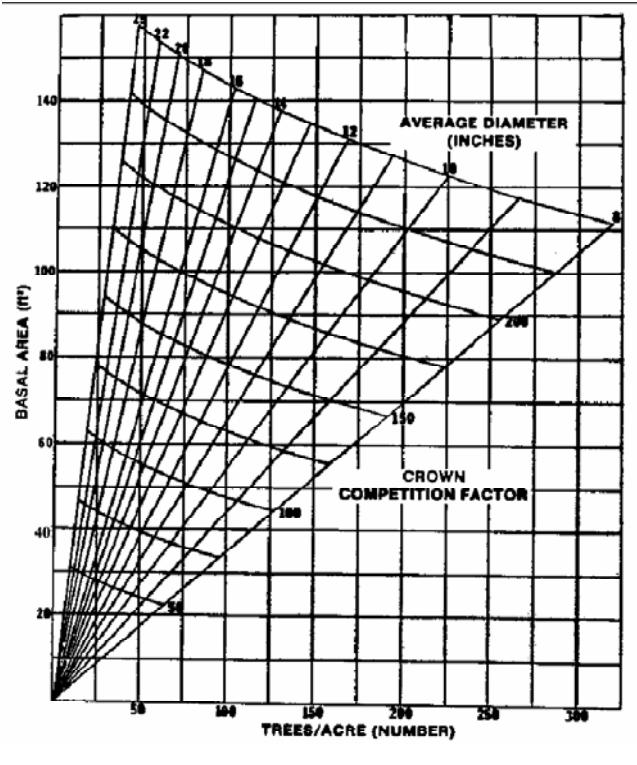
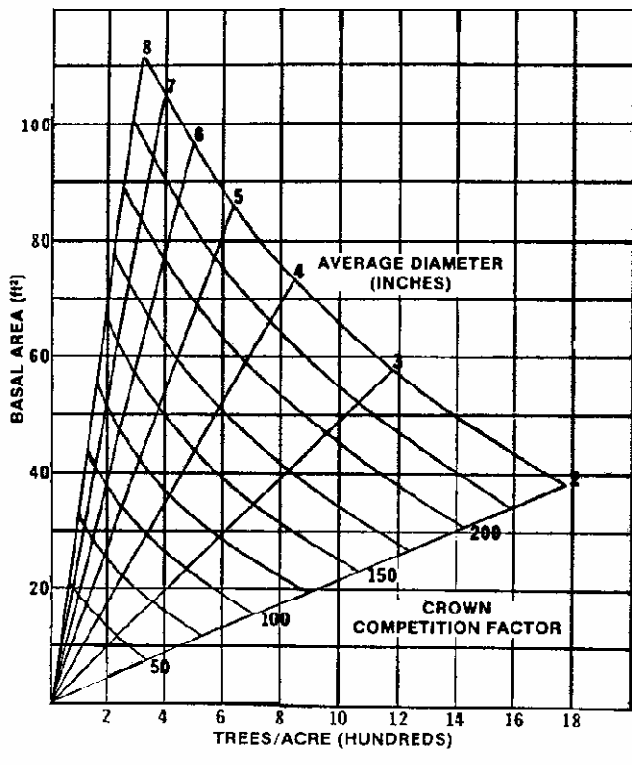

## FOREST TYPE AND STOCKING CHARTS SWAMP HARDWOOD FOREST

**Stand Composition:** The major components of this type include black ash, American elm, and red maple.

### Stocking Levels for Swamp Hardwoods

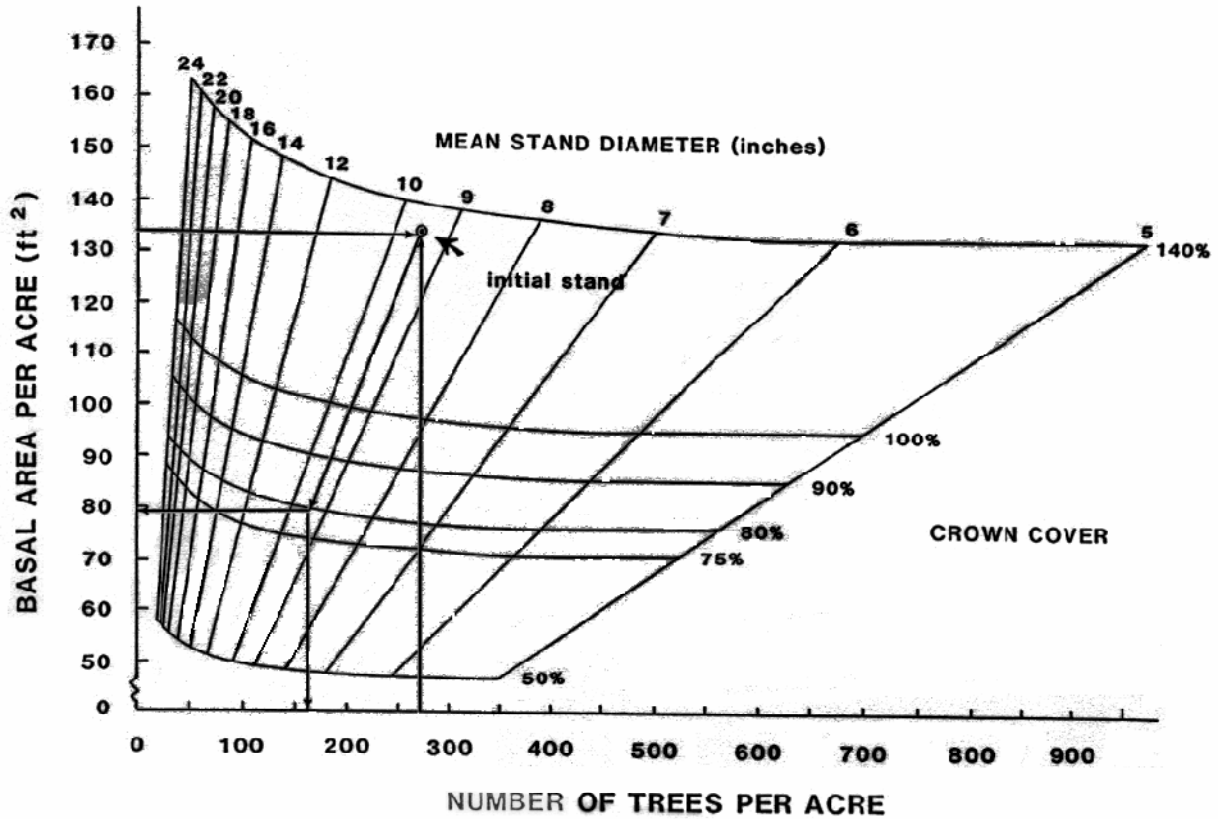



## FOREST TYPE AND STOCKING CHARTS

### BOTTOM LAND HARDWOOD FOREST

**Stand Composition:** The major commercial tree species are eastern cottonwood, green ash, river birch, swamp white oak, silver maple, and American elm.

The bottomland hardwood type is associated with flood plains and stream/river bottoms, primarily in the southern two-thirds of Wisconsin. When the bottomland hardwood community is found further north, it can be regionally significant and may provide important habitat for uncommon or rare species.

**Stocking Levels for Bottom Land Hardwoods** - No Stocking Table available for this forest type.

## FOREST TYPE AND STOCKING CHARTS

### ASPEN FOREST

**Stand Composition:** Aspen comprises more than 50% of the basal area in sawtimber and poletimber stands or more than 50% of the stems in sapling and seedling stands. Principal species are bigtooth aspen and trembling aspen.

**Associated Species:** red maple, paper birch, balsam fir, red oak, and white pine. Most other major tree species occurring in Wisconsin can be found as occasional associates in aspen stands.

**Stocking Levels for Aspen** - No stocking table available for this forest type.

## FOREST TYPE AND STOCKING CHARTS RED MAPLE FOREST

**Stand Composition:** Red Maple comprising more than 50 percent of the basal area in pole timber and sawtimber stands or more than 50 percent of the stems in seedling and sapling stands.

**Associated Species:** Paper Birch, Northern Red Oak, Northern Pin Oak, Quaking Aspen, Large Tooth Aspen, Black Oak, Black Cherry, Bitternut Hickory, Shagbark Hickory, White Pine, Eastern Hemlock, and White Spruce.

### Stocking Levels for Red Maple

